

Trade Scales Limited



Ishida Platform Weighing Systems

IWB

Features

Constructed of waterproof stainless steel, the versatile IW series is ideal for food processing applications - from agricultural and fishery industries to wholesaling and retailing industries



Waterproof Design Conforms to IP-67

The IW-Series meets IP-67 requirements, even allowing washdown for highest sanitary conditions.

Sturdy, Stain, Chemical, and Corrosion Resistant Waterproof Load Cell Conforms to IP-67.

This outstandingly durable weighing unit can be washed and sprayed with water, allowing for easy cleaning. For the first time in the industry the load cell has been coated with acrylic resin to make it completely waterproof.



- Can be operated for 1,000 hours with only 2 size D alkaline dry batteries. (AC adapter can be used too.)
- Has weight checking function for accurate weighing.
- Large character height (36.5 mm)

Specifications

| | | |
|--|---|---------------------------|
| Model | IWB-6 | IWB-30 |
| Capacity | 6 kg | 30 kg |
| Minimum Graduation | 0.001 kg (0-3 kg) | 0.005 kg (0-15 kg) |
| | 0.002 kg (3-6 kg) | 0.01 kg (15-30 kg) |
| | Multi interval | |
| Display | LCD | |
| Weight Check | over, accept, under | |
| Weight | 4.7 kg | Excluding 2 dry batteries |
| | | 9.1 kg |
| Waterproof Construction | IP-67 | |
| Power Supply | 2 dry batteries or AC adapter | |
| Standard Interface | External buzzer or RS232C and relay output signal (except IWB-Series) | |
| Option | RS232C cable, relay output box (except IWB-Series) | |
| Safety Approval | UL, CE, c-Tick | |
| *1. Console for IWQ series is IP-65. | | |
| *2. Battery performance varies depending on its manufacturer, preservation, temperature, and condition of usage. | | |

Trade Scales Limited

| | |
|-------------------------|---|
| Model | IWB-150 |
| Capacity | 150 kg |
| Minimum Graduation | 0.02 kg (0-60 kg) 0.05 kg (60-150 kg) |
| Display | LCD |
| Weight Check | over, accept, under |
| Weight | Excluding 2 dry batteries 16.5 kg |
| Waterproof Construction | IP-67 |
| Power Supply | 2 dry batteries or AC adapter |
| Standard Interface | External buzzer or RS232C and relay output signal (except IWB-Series) |
| Option | RS232C cable, relay output box (except IWB-Series) |
| Safety Approval | UL, CE, c-Tick |

*1. Console for IWQ series is IP-65.

*2. Battery performance varies depending on its manufacturer, preservation, temperature, and condition of usage.

Dimensions

IWB-6

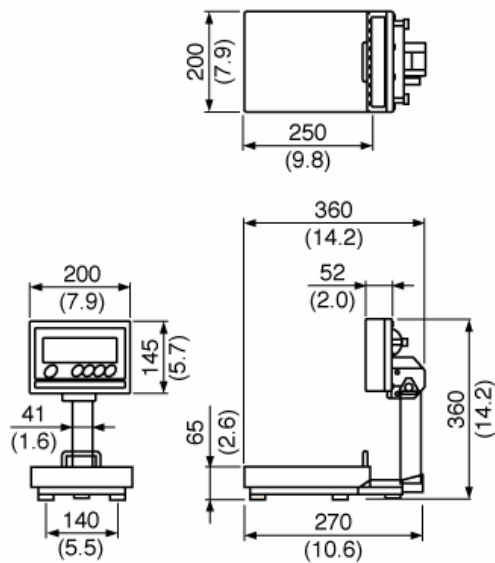

IWB-30

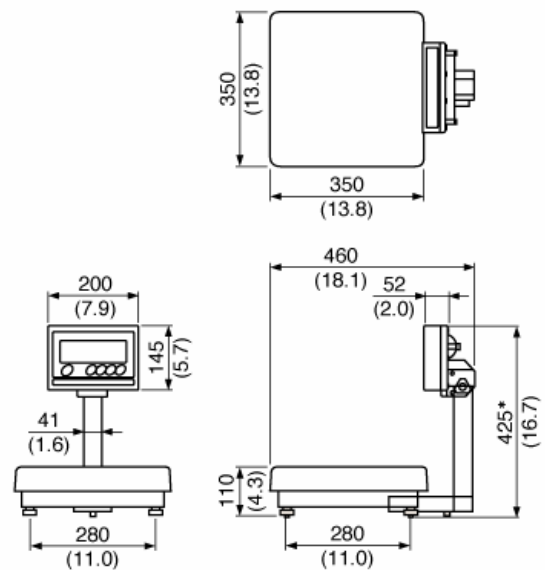

• Height in Australian specification

IWB-30: 755 mm (29.7 in.) / IWB-150: 900 mm (35.4 in.)